



EtherTerminal Model ET-1

Ethernet to Serial Converter
Single port Terminal Server

Etherterminal One Product Manual



Functional Overview

The ET-1 bridges the gap between and your LAN-connected PC and just about any device that communicates by a standard RS-232 port.

In a typical application, the ET-1's ethernet port connects to a hub or switch on your Local Area Network. The RS-232 port of the ET-1 connects to the serial port of the device you wish to have network-based connectivity to.

On the etherstuff.com website, we provide Etherset, the ET-1 configuration utility free of charge. This utility makes the one-time setup of the ET-1's IP address and serial parameters a breeze. Once the ET-1 has an IP address, you can also control the characteristics (baud rate, start and stop bits, parity) of the serial port using the ET-1's built-in Webserver. Simply use any web browser to go to the IP address you've already set up for the ET-1.

The ET-1's serial port is electrically just like your PC's RS-232 serial port. It has a male D-Sub 9 pin connector configured as a DTE device (just like most PCs). It can operate over a range of standard COM port speeds from 1200 baud to 115kbaud.

Once setup is complete, you simply open a telnet connection to the ET-1's IP address and your serial only device is controlled through an ethernet connection.

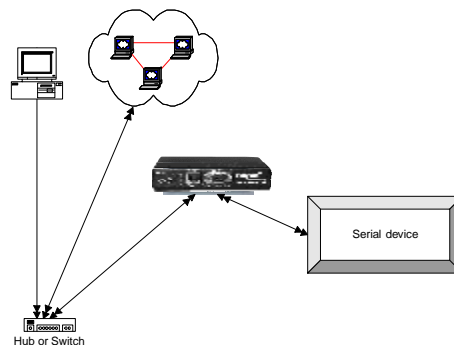

Devices that require serial device drivers in Windows can also be connected using the ET-1 if you install the optional COM port redirector software.

SETUP:

1) Connect your ET-1 to your LAN.

The LAN connection is accomplished by running a standard (straight-through) patch cable from the ET-1's ethernet (RJ-45) port to an ethernet port on your LAN.

2) Give your ET-1 an IP address.

Your ET-1 needs a static IP address. If you are not certain of the IP address to assign to your ET-1, ask your Network administrator. **ASSIGNING AN IP ADDRESS ALREADY IN USE BY ANOTHER DEVICE COULD RESULT IN COMMUNICATIONS PROBLEMS WITH THE OTHER DEVICE OR THE ET-1.**

Fortunately it is very simple to set up all of the configurable parameters for your ET-1 using the Etherset Utility.

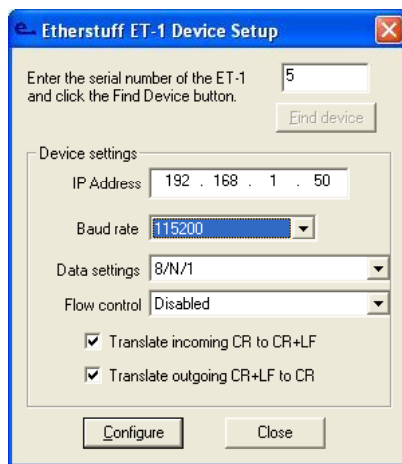

The Etherset utility available free from www.etherstuff.com (Windows 95 or later) is the best and easiest way to get started. Simply enter your ET-1's serial number, click **FIND DEVICE**, and set the options as needed. Then click **CONFIGURE**. It's that simple.

Note: The factory default IP address is set to 0.0.0.1 or 0.0.0.0 (unroutable IPs) to avoid inadvertant conflicts on customers' networks.

Configuring the ET-1 Serial Port

The web interface on the ET-1 contains another simple way to change serial communications parameters. Use any web browser and connect to the IP address you set up for the ET-1.

Click on **Configuration**. Set the parameters to match those required by your serial device then click **Save Configuration**.

Here you may also set Simple Telnet Security options, check status of a connection, and view connection statistics.

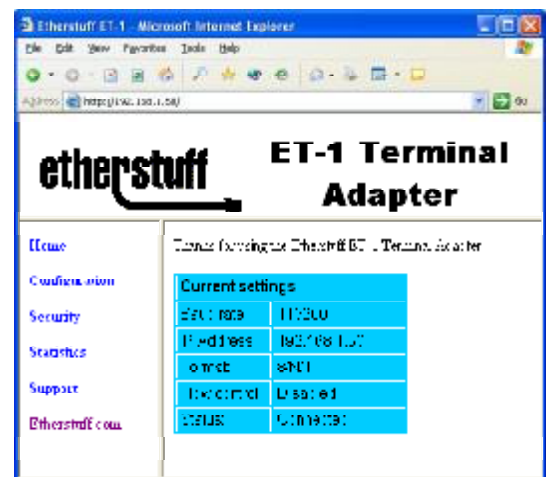

Connecting the ET-1 to your Serial Device

The serial connection is accomplished using a straight-through serial cable with a 9pin female on one end of the cable - for the ET-1's serial port - to whatever your serial device needs for a serial connection (usually a D-Sub 9 or 25 pin) on the other end. The ET-1 is a DTE device; if you are connecting it to another DTE device (like a PC serial port) you may need to use a "null modem" cable, which crosses send and receive data and handshaking.

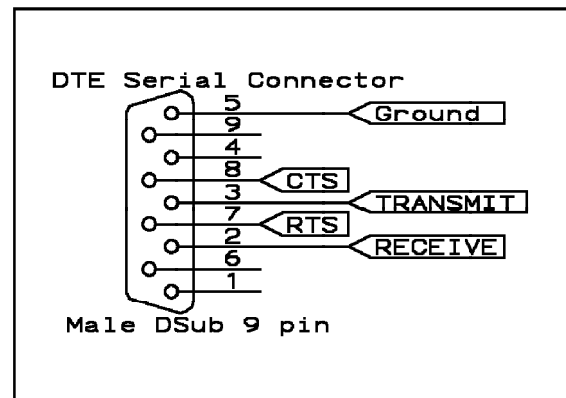

The ET-1's serial connector pinout.

Communicating with your Serial Device

Now that your ET-1 is configured and set up, you should be able to access your Serial-Only device over your LAN using a telnet session in "RAW" or "COOKED" mode..

Open a Telnet session to the IP address you set up for your ET-1; anything you type in the telnet session is sent to the serial device connected to the ET-1. ASCII text sent out by the serial device is also displayed on your Telnet screen. Characters received serially by the ET-1 are transmitted immediately (via the Telnet connection).

NOTE: Most telnet programs default to Line-Buffered mode, which means that characters you type are not transmitted until you press enter. If desired, this option can be changed in your telnet software's configuration.

Proprietary communications software which expects a local COM port can be accommodated by installing a COM port redirector utility. Coming soon to www.etherstuff.com.

Technical note: "RAW" vs. "COOKED" Mode

By default Telnet programs make connections on port 23 using the "cooked" Telnet protocol (RFC 854). The ET-1 also supports RAW mode connections on port 3001.

Troubleshooting

The power indicator normally blinks its “heartbeat” at approx 1 beat (blink) per second. If the Heartbeats stops with the power indicator on, contact Etherstuff service.

If the power indicator is not on and the XMT and/or Rcv indicator does not light up when the unit is connected to an active LAN connection, check for proper power supply operation.

Warranty and Disclaimers

Etherstuff products enjoy a 1 year limited warranty against manufacturing defects. Damage caused by abuse will not be covered by this warranty.

Disclaimer: The manufacturer reserves the right to make changes to this document or the product it describes without notice. The manufacturer shall not be liable for editorial or technical errors made herein. The manufacturer shall not be liable for incidental or consequential damages resulting from the furnishing, performance, or use of the product or this document.

Specifications:

Power Supply	
Voltage	9 - 12V DC or AC (internal rectifier/polarity protection)
Current requirements	~50milliamps at 9-12 VDC
Ethernet Interface	10BaseT
Protocols	Telnet, HTTP
Serial Interface:	EIA RS-232E / V.28
Baud rates supported	1200-115,200 baud
Data Format	7/ODD/1, 7/EVEN/1, 8/NONE/1
Handshaking	RTS/CTS, Xon/Xoff, None
Web Interface:	
Serial setup	Select Baud rate, data format, and handshaking
CR and LF translations	incoming CR to CR+LF, outgoing CR+LF to CR
Connection statistics	Webserver tracks connections since powerup and data sent and received, both ethernet and serial

Etherstuff Information

Etherstuff, 4528 Saugus Ave. Suite 830, Sherman Oaks, CA 91403